

Universal Accumulator Precharging Nitrogen Kit



CODE	Note	Nitrogen bottle adaptor included
12970 - VGLKITAZ	Plus Model	W21,7x1,814 France and W24,32x1,814 Germany

The universal nitrogen tester and pressurize is an indispensable instrument for the verification, pressurization and nitrogen bleeding of most of the hydraulic accumulator available on the market.

To use this unit, screw it on the inflation valve of the accumulator and connect a high-pressure hose to nitrogen bottle.

Kit Weight: 3,90 kg - Model - 12970 – VGLKITAZ

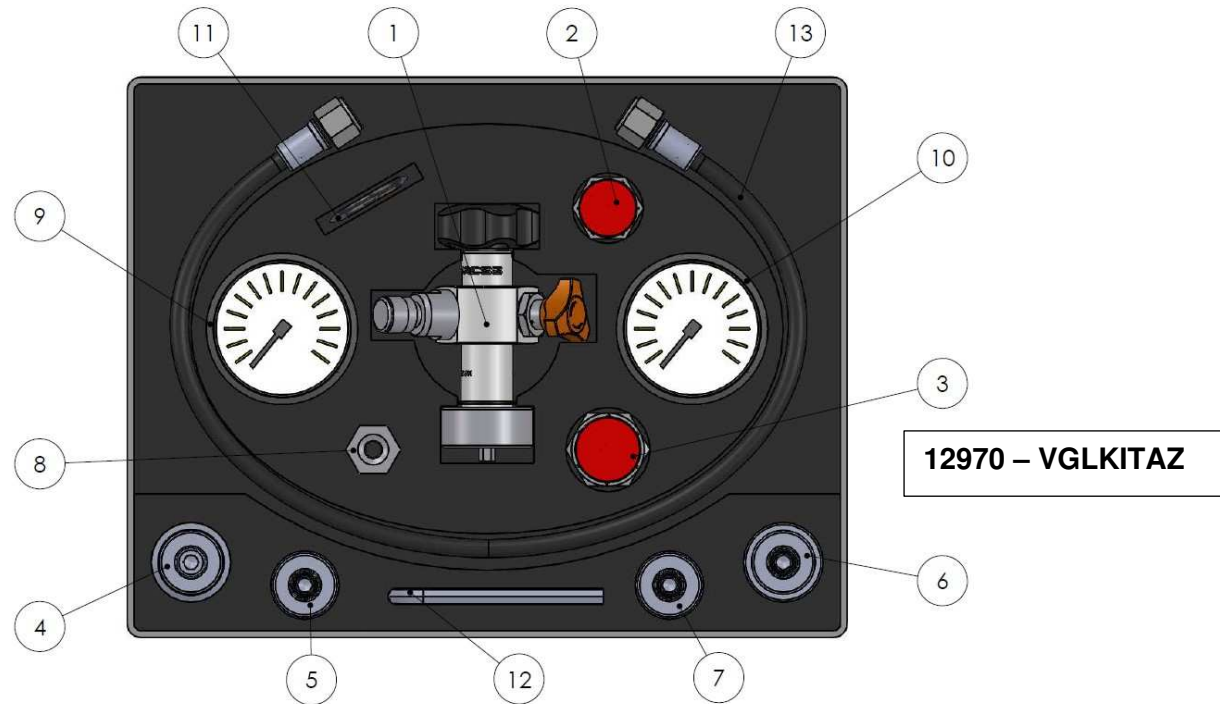

Standard kit Components:

Description	note	N°item
Plastic case		Grey
Charging tool shell – Pmax 400bar	M28 x 1,5	1
Flexi tube about 2m – Pmax 400bar	¼ - ¼	13
Bottles adaptor (please check manufacturer instruction)	P max 200bar	2+3
Pressure gauge with glycerin – test coupling connection	D63mm (0-25) Bar	9
Pressure gauge with glycerin – test coupling connection	D63mm (0-250) Bar	10
Gasket set of precharging kit		11
Nitrogen accumulator valve adaptor	M28x1,5 – 5/8" 18 UNF	7
Nitrogen accumulator valve adaptor	5/8" 18UNF – 5/16 (8V1) Schrader valve	8
Nitrogen accumulator valve adaptor	M28x1,5 – M16x2	4
Nitrogen accumulator valve adaptor	M28x1,5 – 7/8" 18 UNF	5
Nitrogen accumulator valve adaptor	M28x1,5 – ¾"	6
Hexagon socket screw	Key 6mm	12

BLEED VALVE FOR
PRESSURE REGULATION

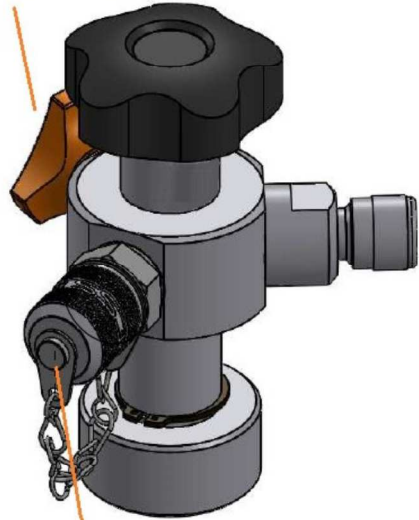

INPUT VALVE

TEST POINT FOR
MANOMETER
CONNECTION

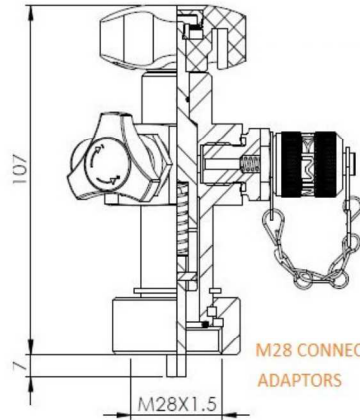

M28 CONNECTOR FOR ALL THE
ADAPTORS

ADAPTORS FOR BOTTLE CONNECTION

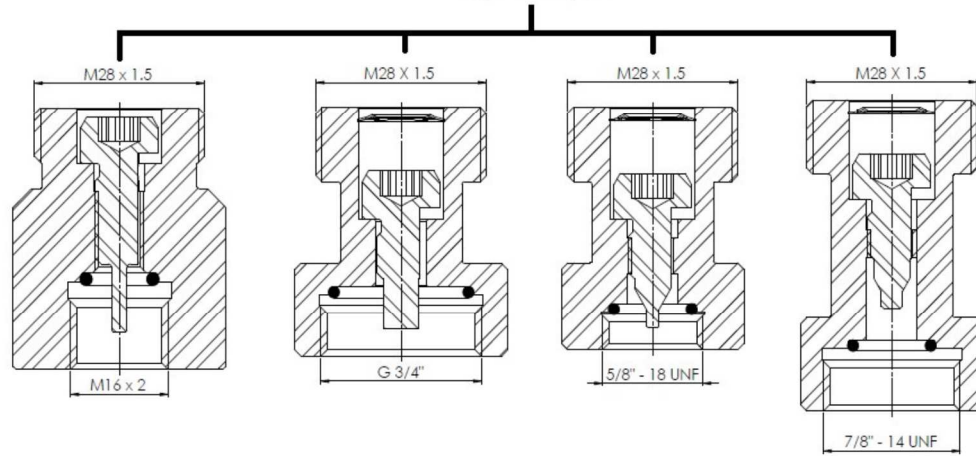
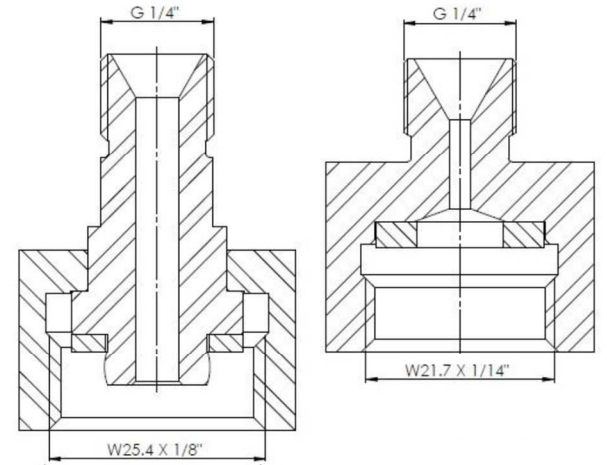

ADAPTOR FOR SHRADER VALVE

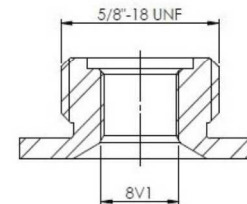

Applications:

- Accumulators inflation
- Accumulators inflation after the replacement of the bladder
- Accumulators pre-charge periodic check
- Accumulators pre-charge check during the installation phase
- Accumulators pre-charge variation

Safety Instructions:

Before any use of the precharging kit tool, carefully read the direction and safety instruction in this guide

In any case, observe the pressure limits indicated on the various appliances. If necessary, refer to the applicable operating instruction.

Before any nitrogen pressurization measurement, the accumulator of the hydraulic circuit under pressure has to be isolated and discharge on the hydraulic side. If required, immobilize it and define the safety zone.

Only use the nitrogen purity $\geq 99,8\%$ N₂ to pressure the accumulators.

The installation of a pressure reducer between the nitrogen bottle and the tester and pressurizer is mandatory.

The VGLKITAZ tester and pressurizer is an inspection tool. After using and before re-starting the accumulator, it has to be removed from the accumulator.

Verifying the Inflation Pressure:

Recommendations: Before proceeding to any operation concerning the initial pressurization of an accumulator, consult the applicable operating instruction.

Pressurization limits: According to models refer to the accumulator manual. The nitrogen pressure varies as a function of the gas temperature. After each inflation and deflation of nitrogen, wait for the temperature to stabilize before checking the pressure. This may last several minutes or several tens of minutes depending on the accumulator size. Never exceed the maximum permissible pressure PS on the maximum inflation pressure Po Max indicated on the accumulator or in the instructions accompanying the appliance.

Accumulator:

- Remove the plug on the inflation valve side of the accumulator
- Select the adaptor according to the inflation valve
- Take the VGLKITAZ shell from the case, install the pressure gauge compatible with the pressure to be verified and make sure the bleed valve in safety closed

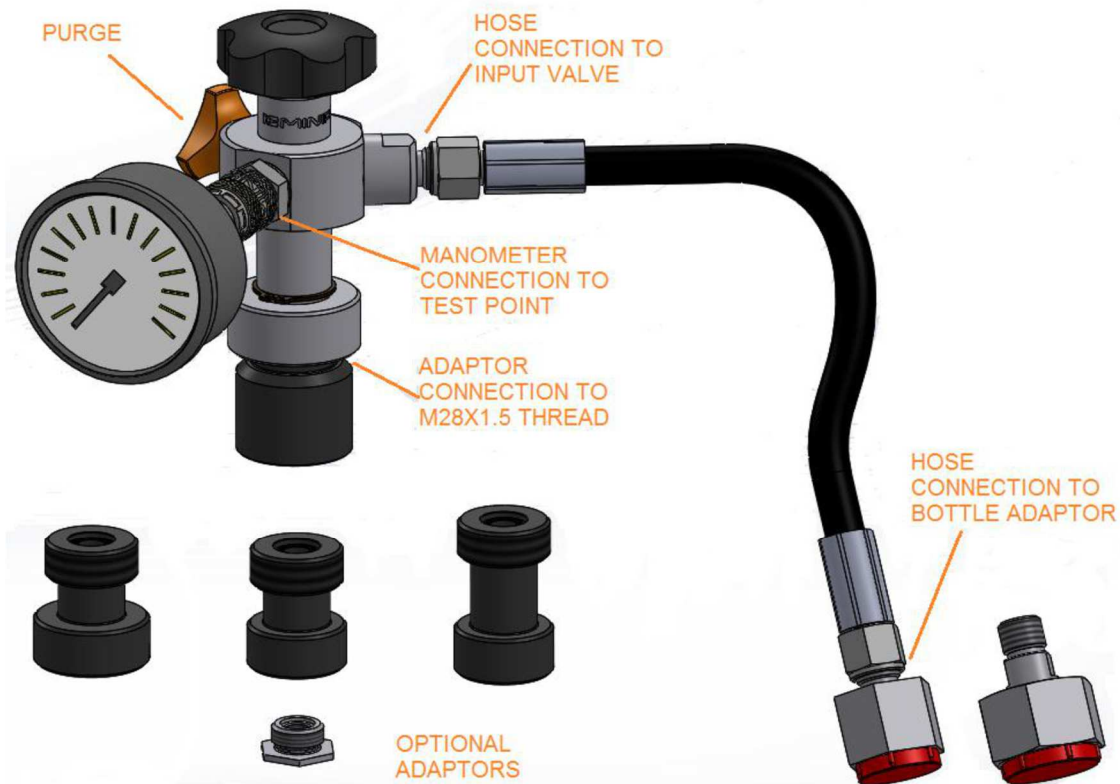

Connection and Operation:

- Connect the bottle to a ¼ "BSPF female end of the fitted hose:
choose the adapter you need for the bottle connection (different country = different adaptor),
screw it on the bottle and proceed with the connection to the female fitting of the hose.
- Take the gauge adapter, remove the plastic dust cap in the ¼ " female thread, take a pressure gauge from the case and screw it onto the gauge adapter.
- Get the charger (item code CARKITAZ) unscrew the metal cap and screw the pressure gauge onto the male thread.
- Choose the accumulator adapter (5/8" 18UNF – M16x2 – 8V Schreuder – 7/8" 14UNF – 3/4" ect.) according to your needs, and screw it on the charger at the female thread M28X1.5.
- Screw the charger onto the accumulator.
- Connect the bottle to the accumulator through the fitted hose.
- Open the passage through the black knob.
- Use the purge to adjust the pressure as needed by rotating the orange knob.
- When the needed pressure is reached (monitor through the pressure gauge), disconnect the fitted hose.
- Make sure that the pre-charge pressure is adequate for the application
- Make sure that the hydraulic pressure never exceeds the maximum allowed value indicated on the accumulator body

Taking into account the temperature influence on the pre-charge pressure: to observe the working pressure to accumulators, it is suggested to adjust the inflation pressure P_o according to the operating or control temperature (see graphic)

Whereby $P_o(t_2)$: inflation pressure at control temperature in Bar (absolute value)
 $P_o(t)$: nitrogen pressure P_o at 20°C in Bar (absolute value)
 T_2 : control of gas inflation temperature
 T_o : reference temperature 20°C

$$P_o(t_2) = P_o(t_o) \times \frac{T_2 + 273}{T_o + 273}$$

Table of the Nitrogen Inflation precharging Pressure according to the operating Temperature

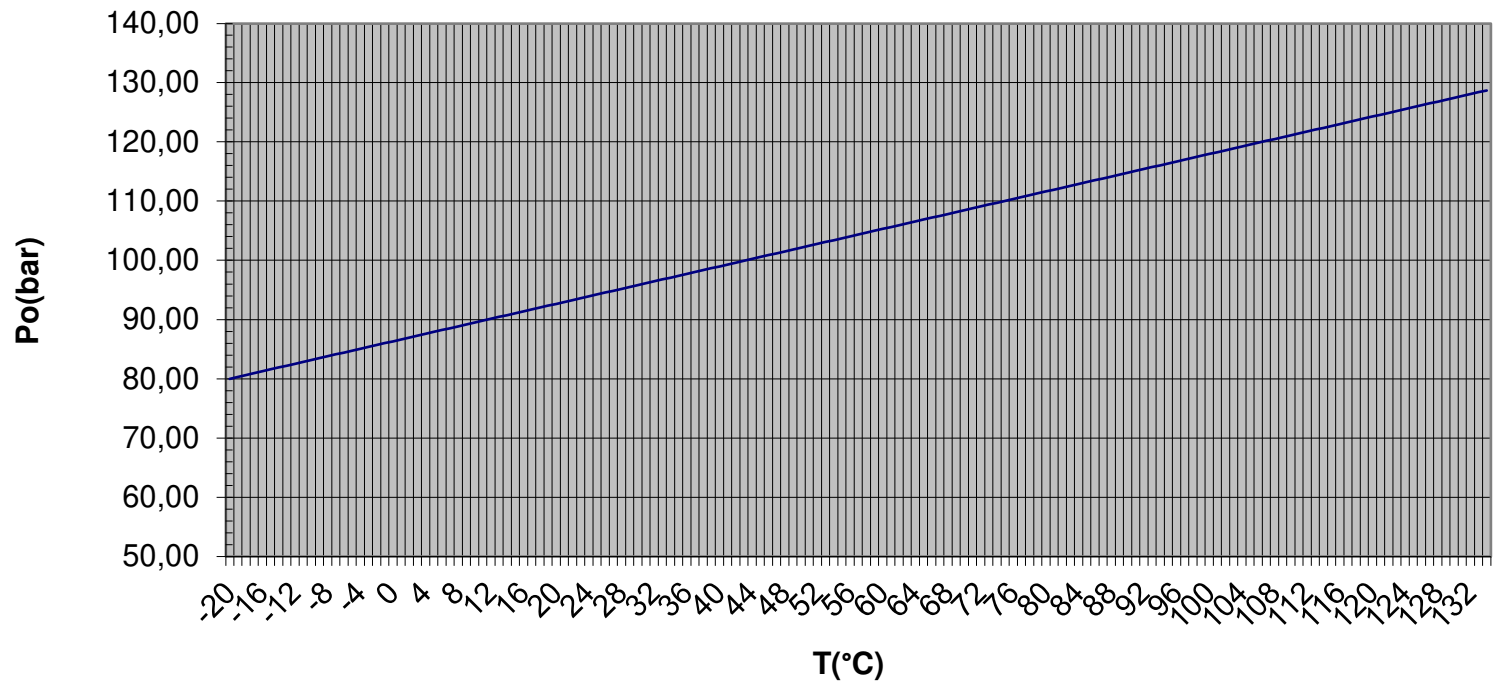

To (C°)	Po (Bar)	To (C°)	Po (Bar)	To (C°)	Po (Bar)	To (C°)	Po (Bar)	To (C°)	Po (Bar)
-20	83,50	11	93,73	42	104,0	73	114,2	104	124,4
-19	83,83	12	94,06	43	104,3	74	114,5	105	124,8
-18	84,16	13	94,39	44	104,6	75	114,9	106	125,1
-17	84,49	14	94,72	45	105,0	76	115,2	107	125,4
-16	84,82	15	95,05	46	105,3	77	115,5	108	125,7
-15	85,15	16	95,38	47	105,6	78	115,8	109	126,1
-14	85,48	17	95,71	48	105,9	79	116,2	110	126,4
-13	85,81	18	96,04	49	106,3	80	116,5	111	126,7
-12	86,14	19	96,37	50	106,6	81	116,8	112	127,1
-11	86,47	20	96,70	51	106,9	82	117,2	113	127,4
-10	86,80	21	97,03	52	107,3	83	117,5	114	127,7
-9	87,13	22	97,36	53	107,6	84	117,8	115	128,1
-8	87,46	23	97,69	54	107,9	85	118,2	116	128,4
-7	87,79	24	98,02	55	108,3	86	118,5	117	128,7
-6	88,12	25	98,35	56	108,6	87	118,8	118	129,0
-5	88,45	26	98,68	57	108,9	88	119,1	119	129,4
-4	88,78	27	99,01	58	109,2	89	119,5	120	129,7
-3	89,11	28	99,34	59	109,6	90	119,8	121	130,0
-2	89,44	29	99,67	60	109,9	91	120,1	122	130,4
-1	89,77	30	100,00	61	110,2	92	120,5	123	130,7
0	90,10	31	100,33	62	110,6	93	120,8	124	131,0
1	90,43	32	100,66	63	110,9	94	121,1	125	131,4
2	90,76	33	100,99	64	111,2	95	121,5	126	131,7
3	91,09	34	101,32	65	111,6	96	121,8	127	132,0
4	91,42	35	101,65	66	111,9	97	122,1	128	132,3
5	91,75	36	101,98	67	112,2	98	122,4	129	132,7
6	92,08	37	102,31	68	112,5	99	122,8	130	133,0
7	92,41	38	102,64	69	112,9	100	123,1	131	133,3
8	92,74	39	102,97	70	113,2	101	123,4	132	133,7
9	93,07	40	103,30	71	113,5	102	123,8	133	134,0
10	93,40	41	103,63	72	113,9	103	124,1	134	134,3