

TIPO TYPE	Cilindrata cm <sup>3</sup> /giro Displacement cm <sup>3</sup> /rev	A	B	Pressione Max. bar Max. Pressure bar			Velocità Max. gir/min Max. Speed rpm	Velocità Min. gir/min Min. Speed rpm	Codice / Code : Rotazione Sinistra - Left Rotation	Codice / Code : Rotazione Destra - Right Rotation
				P1	P2	P3				
LV 1P/0.9	0,91	62	37,25	270	290	310	4000	700	L1P 16 01 F BB A	L1P 16 02 F BB A
LV 1P/1.2	1,17	63	37,75	270	290	310	4000	700	L1P 17 01 F BB A	L1P 17 02 F BB A
LV 1P/1.7	1,56	64,5	38,5	270	290	310	4000	700	L1P 18 01 F BB A	L1P 18 02 F BB A
LV 1P/2.2	2,08	66,5	39,5	250	270	290	4000	700	L1P 20 01 F BB A	L1P 20 02 F BB A
LV 1P/2.6	2,6	68,5	40,5	250	270	290	4000	700	L1P 21 01 F BB A	L1P 21 02 F BB A
LV 1P/3.2	3,12	70,5	41,5	250	270	290	4000	700	L1P 23 01 F BB A	L1P 23 02 F BB A
LV 1P/3.8	3,64	72,5	42,5	250	270	290	4000	700	L1P 25 01 F BB A	L1P 25 02 F BB A
LV 1P/4.3	4,16	74,5	43,5	230	250	270	4000	700	L1P 27 01 F BB A	L1P 27 02 F BB A
LV 1P/4.9	4,94	77,5	45	230	250	270	4000	700	L1P 29 01 F BB A	L1P 29 02 F BB A
LV 1P/5.9	5,85	81	46,75	210	230	250	3500	700	L1P 31 01 F BB A	L1P 31 02 F BB A
LV 1P/6.5	5,85	83,5	48	200	220	240	3500	700	L1P 32 01 F BB A	L1P 32 02 F BB A
LV 1P/7.8	5,85	87,5	50	190	210	230	3500	700	L1P 34 01 F BB A	L1P 34 02 F BB A
LV 1P/9.8	5,85	96,5	54,5	170	190	210	3500	700	L1P 36 01 F BB A	L1P 36 02 F BB A

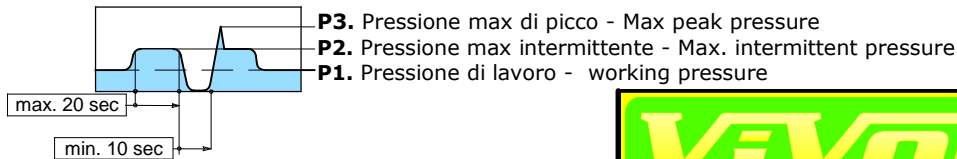
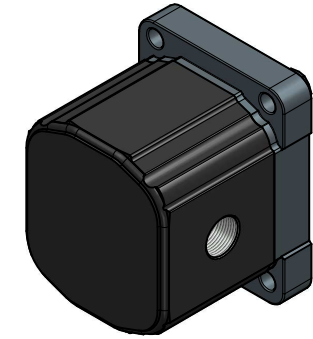
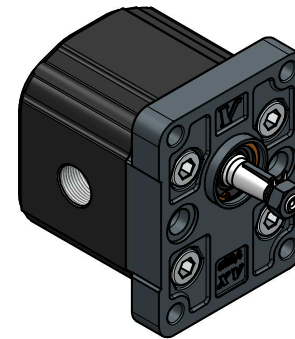

**LINEA KUMA**

**VIVOLO**  
 VIVOIL OLEODINAMICA VIVOLO s.r.l.  
 Società a socio unico  
 Via Leone Ginzburg 2-4 400054 BUDRIO (BO) ITALY  
 Tel +39 051.803689 FAX +39 051.800061  
 www.vivoil.com E-mail: vivoil@vivoil.com

Oggetto POMPA UNIDIREZIONALE BASE STANDARD EUROPEA Ø25.4 ALBERO CONICO 1:8 Ø10 M7x1 CORPO FILETTATO GAS (BSPP)			
d_Disegno : -	Autore ultima modifica: -		Gruppo: -
Data ultima modifica: 23/04/2009	REV. : 1	Disegno: L1P--01FBBA	